



# Understanding the Benefits

## of Using Regenerative Blowers with a Variable Frequency Drive (VFD)

Enhanced Efficiency, Better Performance, and More ...

# Why Use Regenerative Blowers with VFD Devices

---

Whether you're a plant manager, a process engineer, or any other professional working in process automation and streamlining work, using a regenerative blower with a VFD device is a great choice.

Why? Because while Gast regenerative blowers are already very efficient, due to their design which helps the impeller blade maintain a high acceleration, their efficiency can be enhanced even more by using a Variable Frequency Drive, or VFD, which adjusts the AC motor speed and torque in the blower to reduce its speed and power consumption.

A VFD can help you run your regenerative blowers at a lower speed for low-throughput applications, and reach maximum speed when the most power is required – which has a number of benefits.

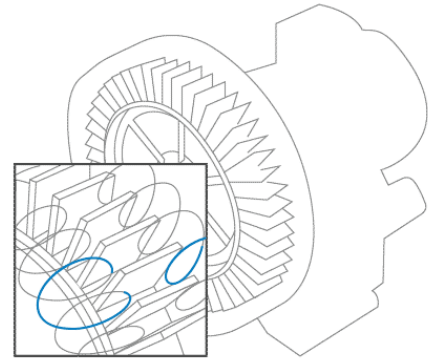

# 4 Benefits of Using Regenerative Blowers with a VFD

---

VFDs are built to enhance the efficiency of electric motors in industrial applications – making them a perfect pair with regenerative blowers.

A VFD allows you to match your blower speed with the requirements of your application. Not all industrial applications require you to use the full speed of your Gast regenerative blower – but if it's running at full power, you'll be wasting quite a bit of energy.

As a matter of fact, the energy that is required to operate a blower increases with the cube of the speed. That means that a blower running at 100% consumes about 50% more energy than a blower that is running at 80% speed – not 20%, as you may assume.

By using a VFD to change the speed of your regenerative blower, you can enjoy the following four benefits – and quite a few more.

## 1 Save Money on Power

This is the most obvious benefit. The biggest cost associated with blower systems is not the initial capital outlay required to purchase the blower – nor is it maintenance. Together, these two costs make up only about 25% of the total lifetime operating cost of a regenerative blower.

What makes up the other 75% of the cost? Energy. The vast majority of all of your expenditures for your systems will go to power consumption – so if you can lower the operating speed and power consumption of your regenerative blowers using a VFD, you can benefit from massive cost savings.

## Enhanced Efficiency

2

Using 100% of your blower's power when you only need 60% is not efficient. It's wasteful, and the #1 thing that all good plant managers and engineers do is minimize waste, wherever possible.

By using a VFD as a speed control device to reduce the blower's speed output, you can optimize the operation of each of your blower systems. And by using automated sensors and controllers, you can ensure that the blower is able to quickly get back up to full speed when heavy product loads require it to do so.

In addition, this can all be set to happen automatically, using flow sensors, pressure relief valves, and other basic systems in addition to a VFD.

## 3 Fewer Maintenance Requirements

Regenerative blowers have very low maintenance requirements – which is part of their appeal for industrial applications. But they are not “maintenance-free”. Occasionally, work will need to be stopped in order to remove any foreign material, metal burrs, and other accumulated debris, and to change filters and other such disposable components.

If your regenerative blowers are running at 100% capacity full-time, chances are that they are going to require more regular servicing, which increases operating costs. Using a VFD helps reduce wear and tear on critical system parts, meaning less maintenance is required for consistent operations.

## Longer Equipment Lifespan

4

Even the most robust and powerful Gast regenerative blowers have a limited lifespan. They won't last forever. And the harder you run your system, the more likely it is to fail prematurely.

Which blower will last longer – one that runs at 100% for days at a time, or a blower that can adjust its performance to the flow requirements of the system automatically?

The answer is intuitive. The more time a blower spends at its maximum frequency – or even exceeding it – the more wear is placed on its internal components, and the shorter its lifespan will be, even with proper maintenance.

Here's another benefit of using a VFD device and sensors with your regenerative blower – your extra equipment will pay for itself within just a few months.

By using a VFD device like the Parker AC10 or the Parker AC30, as well as automated sensors like Barksdale pressure transducers and Apollo ball valves to maintain varying or constant flow rates, you can start saving money on operating costs and ensure that you're getting the best possible performance from your regenerative blower. And, due to the decreased costs for maintenance, power, and more, these devices will essentially “pay for themselves” in just a short period of time.

# VFD and Regenerative Blowers: A Perfect Pair

---

If you are working to streamline your industrial operations and make them more efficient, using a VFD device with your Gast regenerative blowers is a no-brainer.

While regenerative blowers are already extremely cost-effective, a variable-frequency drive can help you get even more energy savings, reduce the maintenance requirements of your blower, and even allow it to have a longer operational lifespan.

Because of those 5 benefits and many more, you should consider investing in a VFD system for your blowers today!

**Contact a Wainbee representative to discuss our Energy Savings Calculators to help calculate your return on investment.**



[salesinfo@wainbee.com](mailto:salesinfo@wainbee.com)



1-888-**WAINBEE** (924-6233)



Wainbee is a market leader in engineered systems, products and services for motion & control, filtration and automation solutions. With a comprehensive team of sales professionals, technical support and engineering staff coast to coast, we bring innovative and integrated systems, high quality products and customer focused services to help our customers solve their application challenges.